

Carl Hamm

PIPES | PUMPS | SOLUTIONS



BOREHOLE INSTALLATION

Training Manual



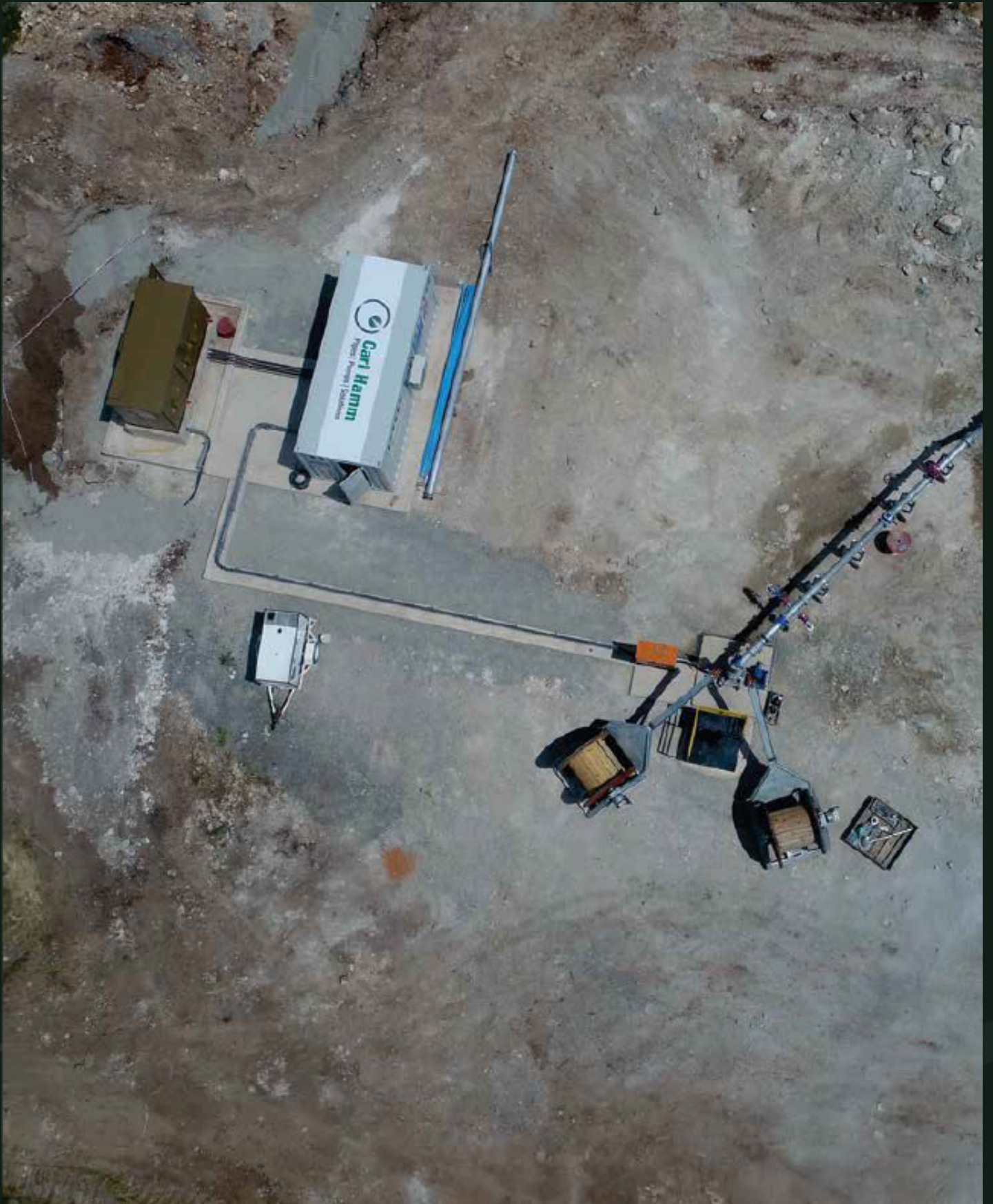

INDEX

Site Preparation & Key Requirements 3

Site works before installation 6

“Best Practices” Off Loading of Carl Hamm ZSM Equipment 10

Step 1 - Placement of Assembling Table 12

Step 2 - Placement of the cable dispensers around the borehole 14

Step 3 - Place the motor in Pump Assembly Stand 16

Step 4 - Preparation work on Motor 18

Step 5 - Connect the Lifting device to the pump and lift the pump into position 20

Use of Check Valves 22

Pipe Centralisers 24

Maric Rate of flow control valve 26

Step 6 - Cable Termination 28

Step 7 - Install the Pump assembly in the well 30

Step 8 - Installation of Carl Hamm ZSM Equipment 32

Step 9 - Connect Riser Pipe with Pump Adaptor 34

Step 10 - Lowering riser pipe and clamp cable with HCL Clamps 36

Step 11 - Connect the ZSM pipe support to Assembling Table 38

Step 12 - Installation of Header Works 40

Startup Methodology Comparison Of Pump Control 42

Step 13 - Electrical Equipment 44



4 Site Preparation & Key Requirements

- Safety file to be compiled and approved by the client.
- Employees to wear mandatory PPE, this includes overalls, safety boots, hardhats, gloves, safety glasses and reflector jackets.
- Plant will be inspected on arrival at site to ensure a safe working environment.
- The area will be Barricaded by means use of red/white danger tape.
- Tools used will be inspected daily before use and records kept in site safety file. Baseline risk assessment (Routine) will be conducted prior to going on site and will be filed int he site safety file.
- Daily risk assessments (ISA) (Non routine) will be conducted prior to any work and will be discussed with employees on site.
- The risk assessment will be available to the client and filed in the site safety file.
- Separate activities will be covered by individual risk assessments which will be presented to the employees carrying out the activity.
- Prior to commencement of work the site supervisor will do a daily risk assessment of the task at hand and communicate the task to the employees prior to work starting. This will be recorded on a standrad document, signed by the employees concerned and the form filed in the safety file, of which a copy will be submitted to the client safety officer, if applicable.
- Ensure that valid calibration and load certifications of the equipment e.g., Slings will be filed in the site safety file prior to use.
- Final inspection to be conducted by Mine site supervisor.
- Rigging and crane operations to be conducted by a qualified person(s) supplied by the mine.
- Rigging study to be conducted by qualified rigger to determine the lifting path and method of lifting ZSM Riser pipes.
- Ensure that the installation team is familiar with the scope of work as per method statement and that all risks are mentioned to the team and signed off by all members.
- Ensure the Mobile crane is in position correctly as per rigging study to be done before any lifting can start.
- Ensure that the ZSM riser pipes are safely stacked for the crane to reach.
- Check lifting weight, crane position with capacity of applied crane, based on crane specification issued by manufacturer.

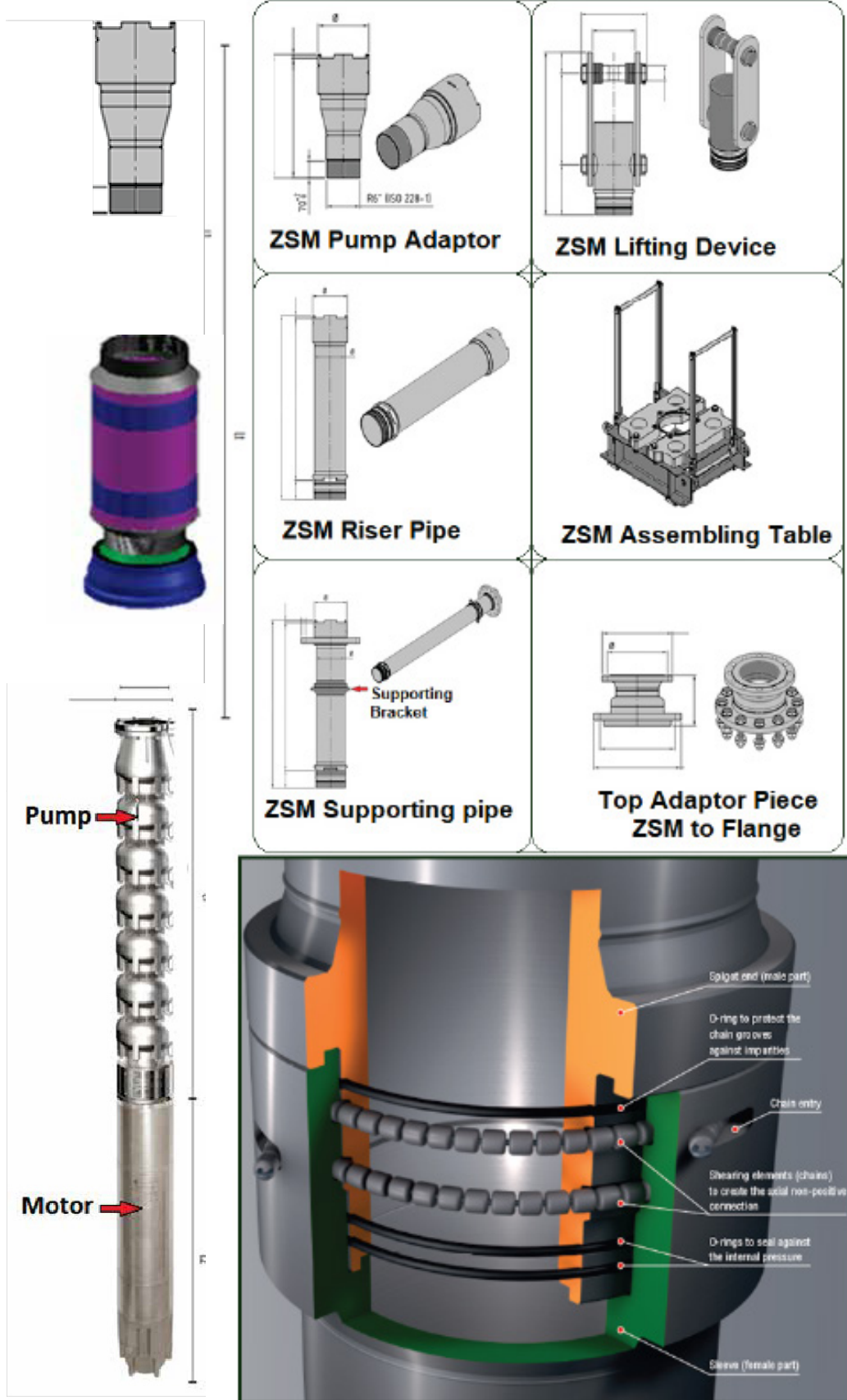

6 Preparation works before installation.

Pump and Motor:

- Correct pump and motor need to be selected Flow vs Head.
- Double check the pressure rating of the pump non-return valve. If it is not suitable, install additional NRV in the vertical installation.

ZSM Pump Adaptor:

- Pump adaptor is the first connection between Pump unit and ZSM equipment.
- Connects directly in to the Non-Return Valve of the Pump.
- Pump adaptor can be fitted to the threaded end or Flange end.

ZSM riser pipe:

- Riser pipes are required to be installed to reach the total installation depth.
- Riser pipes can be from DN50 up to DN1400.
- The Length depends on requirements from 2m up to 11m.

ZSM Supporting pipe:

- The supporting pipe is the last pipe to be installed. The supporting bracket must be secured to the assembling table, this will carry the full load of the complete column.

Assembling Table:

- The Assembling table is used during installation and is then used for the permanent header which is designed to carry the full load of the ZSM Column with Pump & Motor and Water mass.

Adaptor Piece from ZSM to flange:

- Is the top adaptor which changes from ZSM Coupling to Flange. This is the point where the Header works on Surface will be connected to.

Lifting device:

- Lifting device is used only for installation and maintenance purpose.

Chain Lock:

- There are x2 shearing elements (Chains) to create the axial non-positive connection.

O-Ring:

- There are x3 O-Rings in each coupling set, the top one protects the chain groove against impurities, and the bottom two seal against the internal pressure.

Cover plates:

- The cover plates are placed over the Chain entry to prevent dirt entering the groove.

Screws for cover plates:

- The Screws are used to mount the cover plates over the chain entry.

Additional High Pressure Silent Check Valve:

- 40 Bar Silent Check valve between pump outlet and ZSM adaptor.

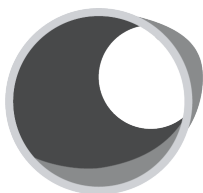
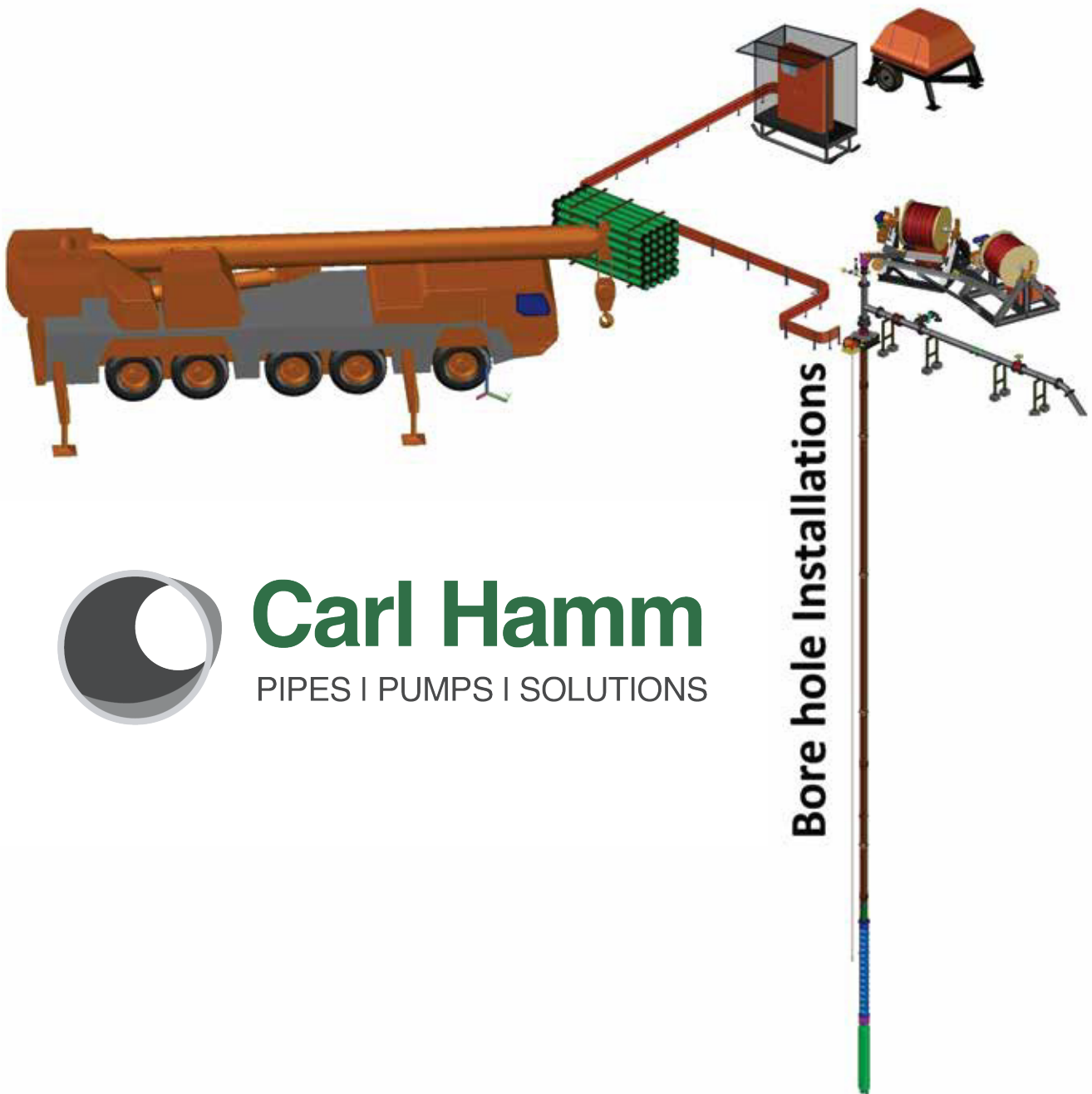

Carl Hamm
PIPES | PUMPS | SOLUTIONS

8 Preparation works before installation.

Checklist Pump and Motor: Before installing be sure to read the OEM user Manual

- This manual contains essential instructions that must be observed during installation, operation, and maintenance. This operating handbook must be read and understood both by the person in charge of assembling the machine and by all qualified personnel appointed by the person responsible for installation to perform its operation. These operating instructions must always be available on site of the machine being used.

1 – Visual Inspection on arrival

- Examine the pump to ensure that no damage occurred during transportation.
- Report any damages or shortages to the freight carrier and note on bill of lading.

2 – Storage

- Storage Temperature from -20°C to +60°C The pump should not be exposed to direct sunlight.
- If the pump has not been packed, it must be stored horizontally, adequately supported, or vertically, to prevent the misalignment of the pump.
- Ensure the motor is always filled with water as per Manual instructions.

3 – Pump Suitability of well

- Submersible pumps, as well as all water pumps, are designed to handle clean, cool, clear water. Water from an undeveloped well often contains excessive amounts of sand, dirt, and other abrasives which can cause damage to the pump.
- Install the pump in a well which has been properly constructed with a test pump. The test pump also provides a means to match the capacity and setting of the pump to the yield of the well. If the pump removes water at a higher rate than the well produces, the draw down will be excessive, and this will cause air to be pumped, and result in damage to the pump or motor.

4 – Installation checks

- Check in the technical catalogue for the maximum diameter of the pump and the pump with motor. Verify the borehole with an inside caliper to ensure unobstructed passage.
- Inspect if the check valve (None-return) on the delivering piping is working.
- Pump should be assembled to the motor at the installation site. Always assemble pump to motor vertically to reduce strain on pump coupling and motor shaft. Assembling the pump and motor horizontally or at an angle may result in damage to the pump shaft, coupling or motor shaft. Use the Pump Stand.
- Lowering of the pump: Verify that the well is not clogged along its total length. Lower the pump into the well, paying attention to not damage the electric cable.

Checklist

- Pump
- Motor
- Cable and Cable Clamp
- Cable Dispenser
- ZSM Equipment
- Make sure free of dust
- Check for Completeness
- Air Release
- Check valve
- Surge Anticipation
- Gate Valve
- Visual Inspection
- Rate of Flow control
- Storage Conditions



Offloading ZSM Equipment as per Method statement

- When Pipe is brought to site careful consideration of the placement of equipment is required. This is to enable and facilitate the easy collection.
- Ensure the Mobile crane is in position correctly as per rigging study to be done before any lifting can start. When considering the crane, a formal "Rigging" study and "Risk assessment" must be done to ensure the size and position of crane is correct.
- The Crane and Rigging equipment must be certified for correct load bearing and must be safety compliant - the licensed Driver and Rigger must have Safety files for their equipment.

Offloading checklist on ZSM Equipment

- The Piping must be stacked in such a manner that the couplings are protected from rubbing and possible damage, and for ease of lifting.
- The ZSM Pipe O-Rings must be kept out of the Sun and weather conditions. Inspection must be performed on the equipment before use, to ensure that O-Rings have not perished.
- The Chains must be stored in a place to protect them against the Sun and Weather.
- Coupling ends must be cleaned before O-Rings are placed on. 6
- O-Rings must be packed and clean and not in direct sunlight.
- Chains must be packed and clean and not in direct sunlight. An Adequate
- Quantity of Petroleum Jelly must be available for installation
- Placement in proximity of Hole and Crane

Placement of the ZSM riser pipes in proximity of Borehole and Mobile Crane

- Ensure the pipes are stacked in the set radius of the crane for the crane to swing in a left to right movement which is aligned with the riser pipe.
- Ensure that a Rigger does a Full Rigging Study with Risk analysis.
- Ensure the Mobile Crane selected is the correct Size according to the Rigging study.
- Ensure the crane position is in the swing proximity of the hole and Mobile Crane.
- Ensure use of the Carl Hamm lifting device by placing the male coupling into the female coupling of the ZSM pipe and secure the connection with the chain lock.
- Fit the jockey wheel on the other end of the male coupling and carefully lift one ZSM riser pipe from the stacked bundle, from a horizontal position, one at a time by slowly rotating the mobile crane's boom back in the same set radius and at the same time lift only the hook vertically.
- Once the Crane boom is in the centre of gravity point, the riser pipe can then be lifted and transported to the borehole.
- Make use of guide ropes to keep the load from swinging out of control.
- Ensure that the Stacked bundles are secured and level before taking each pipe from the stacked bundle.
- Ensure that no unauthorised person is in the lifting path as per rigging study.
- Ensure that the Lifting Zone is demarcated, and that no one is allowed underneath the suspended load.



Placement of Assembling Table

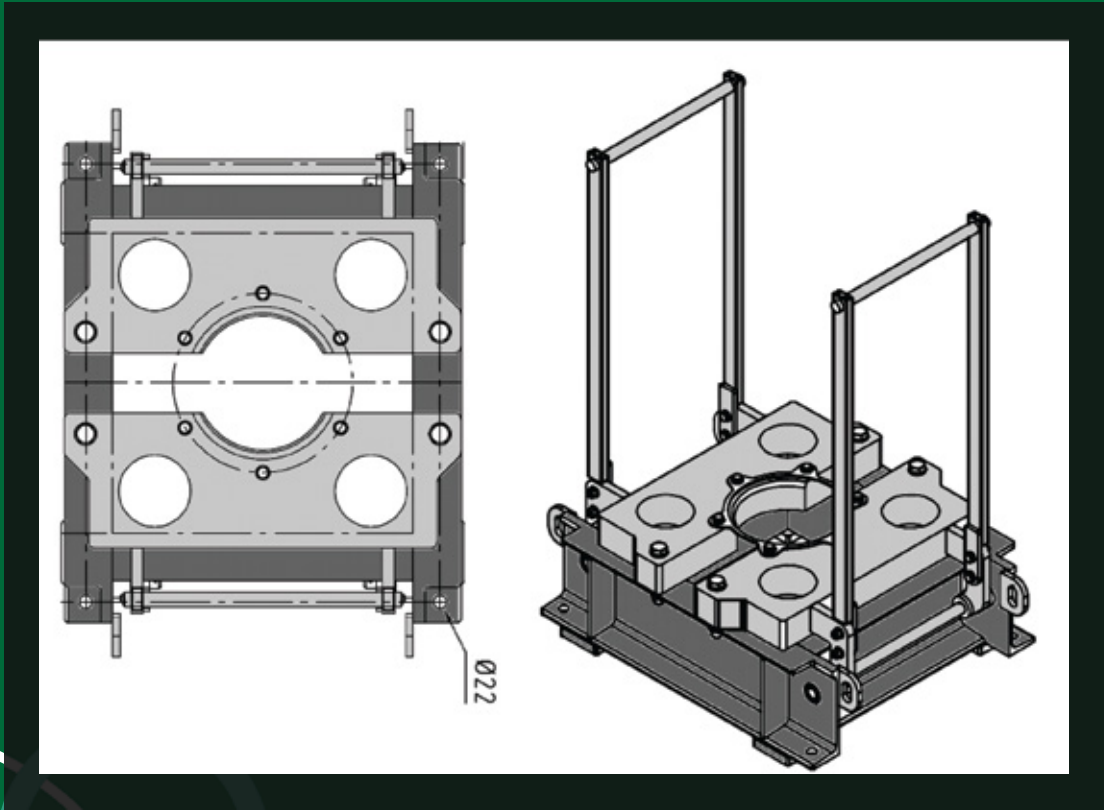

12 Step 1 – Placement of Assembling Table

- Placement of the assembling table over the borehole. Lower assembly onto wellhead base (align holes of head and base) and seat with holes aligned, install and fasten the holding down bolts to the concrete base.
- Centralise the assembling table with the borehole casing to ensure there is even space all around.
- Ensure the assembling table is level and that the holding down bolts are in place, before continuing with the installation.
- Ensure there are no sharp edges on the borehole casing.



Assembling & Placement of Cable Dispensers around the borehole

Step 2 – Placement of the cable dispensers around the borehole

- Cable dispensers are to be positioned on an even surface and are to be aligned with the centre of the bore hole.
- Place all cable dispensers close to the borehole for the extension boom to be positioned next to the riser pipe, which will ensure trouble-free installation.
- This will position the cable directly above the borehole in its correct position. This will also assist with taking the full load of each cable.
- The extension boom will be high enough to allow enough workspace around the bore hole and to allow movement of manpower.
- The slack of the cable will be controlled by the gearbox which eliminates all hazards.
- The shaft will be placed through the centre hole of each cable drum, and reel locking cone will secure and lock the cable drum in the centre of the shaft.

Placement of the cable drum

- Ensure the Main frame is positioned and placed on an even surface.
- Lift the cable drum & shaft with overhead crane and place it on the roller brackets which are fixed to the main frame of the cable dispenser.
- The lid on the roller bracket will then be closed and fastened with a locking pin to ensure the shaft cannot come out while it is in operation.

Installation & Fixing Cable to column

- Using the cable dispensers will allow the installation team to have full control over the handling of the cables when they can then guide the cables to the correct fixing point as per above picture.
- The HCL protector guide can then be placed around the cables and be fixed with the smart tie.
- The Assembling table can then be opened, and the riser pipes will be lowered into the borehole without the risk of damaging the cables.
- The tension on the cables can be contorted by the manual gearbox which can be lowered if the tension is too high and can be lifted if there is too much slack on the cable.

Picture on the left



Motor in Storage

Assembly Stand



ZSM Assembly Table



16

Step 3 – Place the motor in Pump Assembly Stand

- Prepare the ground surface area where the stand will be placed, ensuring that the assembly stand is 100% level. Best practice is to have a concrete base underneath the stand close to the well, if possible.
- Start with preparation work to lift motor from storage wooden crate, and inspect if there is any damage to the wooden crate.
- Lift the motor from a horizontal position to vertical position using suitable lifting equipment (Mobile Crane etc.)
- Remove the motor from packaging by attaching the 2-Leg chain to the Eye-Bolts.
- Lift motor slowly from the horizontal position to the vertical position.
- Examine the motor to be sure no damage occurred during transport or offloading.
- Inspect the Lead-out cables for any damage.
- Slowly move the Motor to the pump assembly stand and place the motor into the tube in the middle of the assembly stand.
- Guide the motor into the tube, always keeping hands outside the danger area between tube and motor.
- Ensure that the lead out cables are guided along with the motor to prevent any damage to the cables.
- Ensure the motor is level before decoupling the sling and removing the eye bolts.

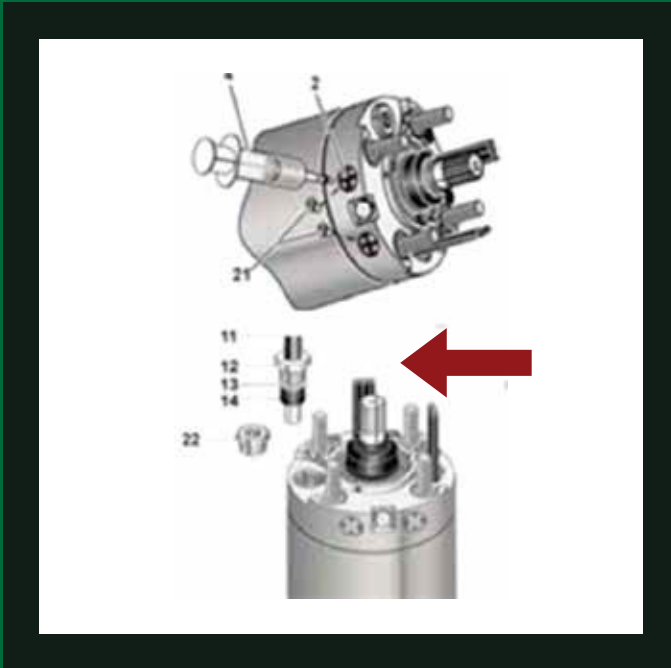

Remove The Plug



Install The PT100

18 Step 4 – Preparation work on Motor

Be sure to read the Pump Manual!

•Start with preparation work on the motor before connecting the Pump.

- Clean the surface of the motor.
- Ensure the rubber seal is in place which protects the mechanical seal.
- Remove the motor shaft protector.
- Make sure that the motor shaft can be rotated manually before assembly continues.

•Fill up the motor as follows.

- Remove the plug from where the PT100 must be installed.
- Top up the motor with motor fluid until it overflows as per manual.

•Installing the PT100

Install the PT 100 as per manual instructions.



ZSM Lifting Device

ZSM Pump Adaptor

Pump

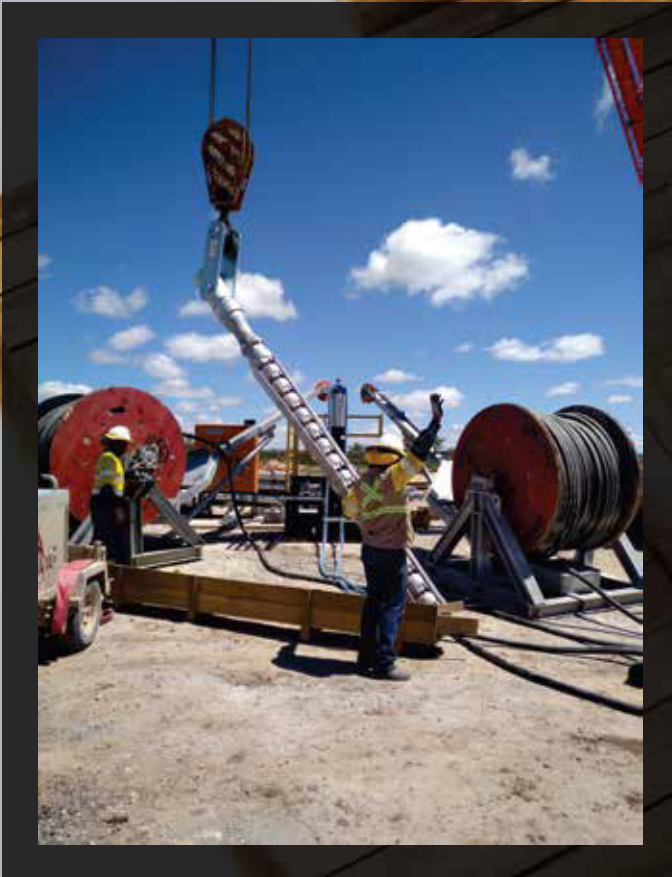

Step 5 – Connect the Lifting device to the pump and lift the pump into position

- Remove the pump from packaging by using slings to keep the pump in a horizontal position.
- Safely place the pump in a horizontal position with the Carl Hamm Pump adaptor which has the ZSM female coupling on the one end and threaded end on the other.
- Remove the cable guards to prevent damage.
- Screw the Carl Hamm pump adaptor directly into the non-return valve of the pump, ensuring that the adaptor is completely screwed in before securing the joint with the Grub screw.
- Connect the Carl Hamm lifting device to the pump unit by placing the male end of the lifting device into the female end of the Pump adaptor while the pump is still in a Horizontal position.
- Secure it with the 2 off chains into its positioned grooves.
- Lift the pump into a vertical position to connect pump and motor as per manual.



It is recommended that one or more check valves always be used in submersible pump installations. If the pump does not have a built-in check valve, a line check valve should be installed in the discharge line within 7.6 m (25 feet) of the pump and below the draw down level of the water supply. For deeper settings, check valves should be installed per the manufacturer's recommendations. More than one check valve may be required, but more than the recommended number of check valves should not be used. Swing type check valves are not acceptable and should never be used with submersible motors/pumps. Swing type check valves have a slower reaction time which can cause water hammer (see next page). Internal pump check valves or spring loaded check valves close quickly and help eliminate water hammer. Check valves are used to hold pressure in the system when the pump stops. They also prevent backspin, water hammer and upthrust. Any of these can lead to early pump or motor failure. *[NOTE: Only positive sealing check valves should be used in submersible installations. Although drilling the check valves or using drain-back check valves may prevent back spinning, they create upthrust and water hammer problems.]*

A. Backspin - With no check valve or a failed check valve, the water in the drop pipe and the water in the system can flow down the discharge pipe when the motor stops. This can cause the pump to rotate in a reverse direction. If the motor is started while it is back spinning, excessive force is placed across the pump-motor assembly that can cause impeller damage, motor or pump shaft breakage, excessive bearing wear, etc.

B. Upthrust - With no check valve, a leaking check valve, or drilled check valve, the unit starts under a zero head condition. This causes an uplifting or upthrust on the impeller-shaft assembly in the pump. This upward movement carries across the pump motor coupling and creates an upthrust condition in the motor. Repeated upthrust can cause premature failure of both the pump and the motor.

C. Water Hammer - If the lowest check valve is more than 9.1 m (30 feet) above the standing (lowest static) water level, or a lower check valve leaks and the check valve above holds, a vacuum is created in the discharge piping. On the next pump start, water moving at very high velocity fills the void and strikes the closed check valve and the stationary water in the pipe above it, causing a hydraulic shock. This shock can split pipes, break joints and damage the pump and/or motor. Water hammer can often be heard or felt. When discovered, the system should be shut down and the pump installer contacted to correct the problem.



Pipe Centralisers

It is recommended to fit 3 or 4 pipe centralisers on the 4 pipes above the pump outlet in order to keep the pump / motor / cable from scraping against a / the side wall and preventing possible damage.



Maric Rate of flow control valve

- The Maric Rate of Flow control valve has been developed to provide a constant pre-set Flow rate, irrespective of pressure fluctuations over a wide range.
- This Maric is an Automatic, maintenance-free, self-cleaning practical solution to installations requiring accurate flow rate - especially when pumping into “Ring Main”.



Megger Test



Cable Terminations

- Cable terminations can run parallel with the connection of the pump and motor.
- Electricians must ensure that the correct connecting sequence is being followed. Read the pump manual or phone the pump manufacturer.
- Ensure that a megger test is done on the motor before the cable termination can continue.
- The Power lead-out cables will then be terminated the two cable drum cables supplied.
- PT100 Cable will also be terminated.

**Open Door of the
Assembly Table**



30 Step 7 – Install the Pump assembly in the well.

- Once the cable terminations are complete, lift the complete pump unit out of the pump assembly stand and move it to the borehole, ensure to guide the cabling.
- Centralise the pump unit with the centre of the assembling table, to guide the cables.
- Manually open the clamp doors by hand of the assembling table and carefully lower the Motor into the borehole at the point where the cables can be reached.
- Slowly lower the motor into the bore casing until the point where the cabling can be reached.
- There will be a single core cable which needs to be tied down next to the pump into the dedicated cable slots, ensure that there are no sharp edges.
- Take the lead out cables with the PT100 and neatly strap it in its dedicated path where the cable guards will keep it secured alongside the pump.
- Ensure to torque the M10 bolts to the correct specification.
- Extra high pressure silent check valve installed straight after pump before ZSM connection.

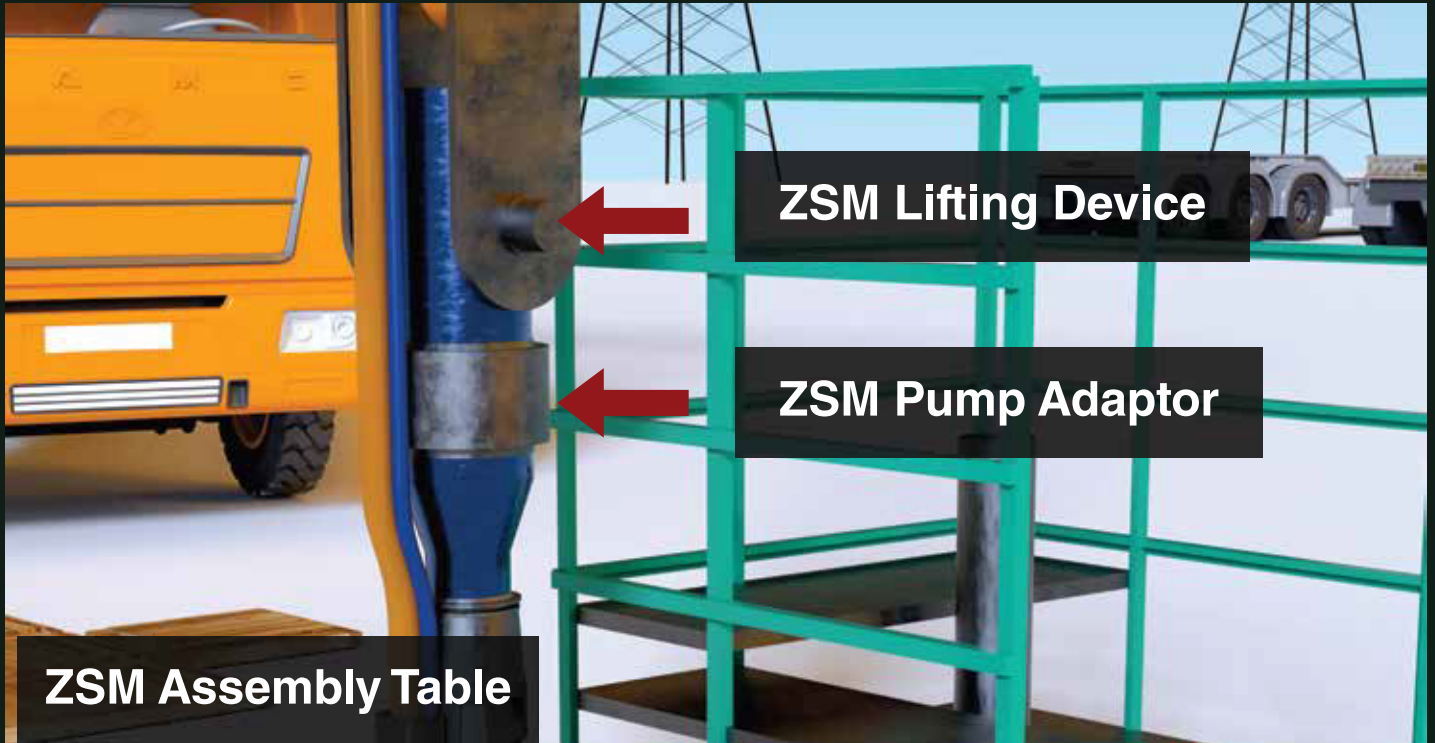

ZSM Assembly Table

ZSM Lifting Device

ZSM Pump Adaptor

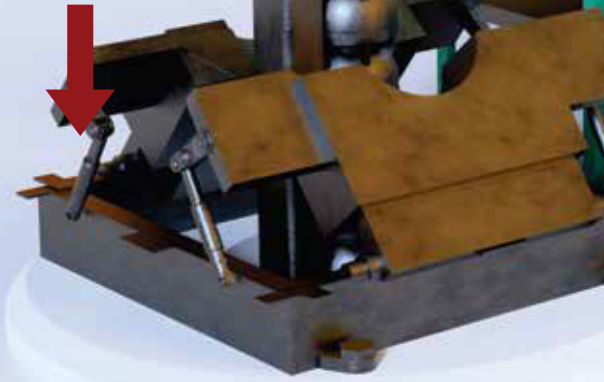

Lower Unit in to Bore Hole



Open Doors

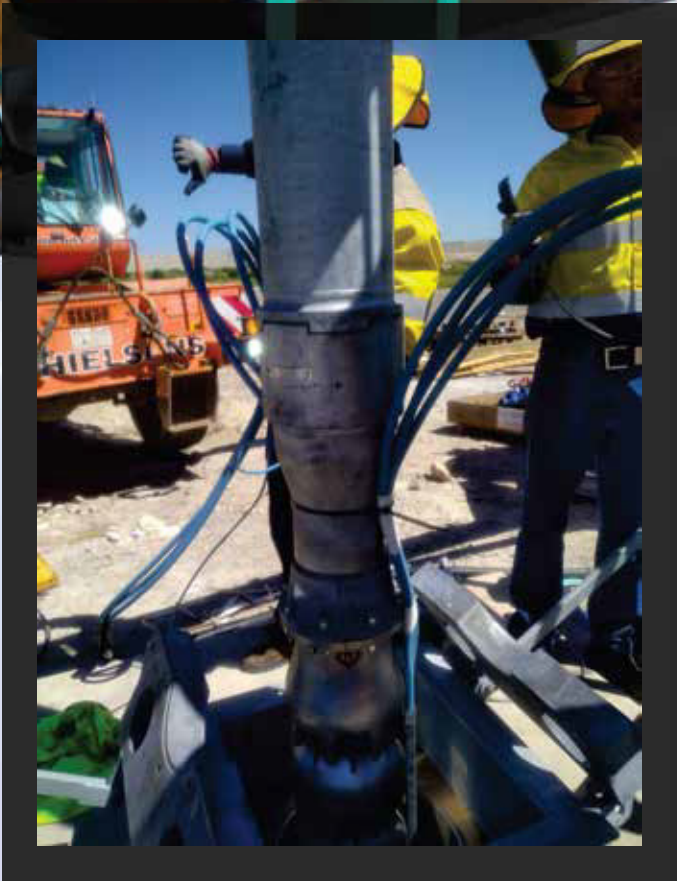

Step 8 – Installation of Carl Hamm ZSM Equipment

- The complete pump unit can then be lowered into the borehole to the point where the ZSM pump adaptor collar reaches the top of the assembling table. Where the doors will be closed and the ZSM collar seats in the slot of the ZSM spacing.
- Ensure that the cables are guided to prevent damage when the doors are closed (ensure cables are lying properly in cable slots before closing doors).
- Remove the 2 chains from the grooves of the ZSM coupling to loosen the Lifting device from the ZSM Pump adaptor with a Mobile Crane, the Pump unit total weight will rest on the assembling table.
- The lifting device can now be used to collect the riser pipe.

ZSM Lifting Device

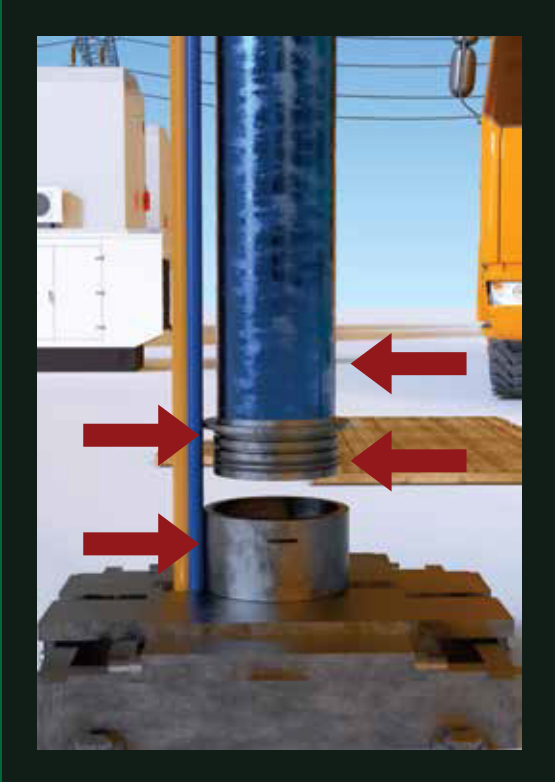
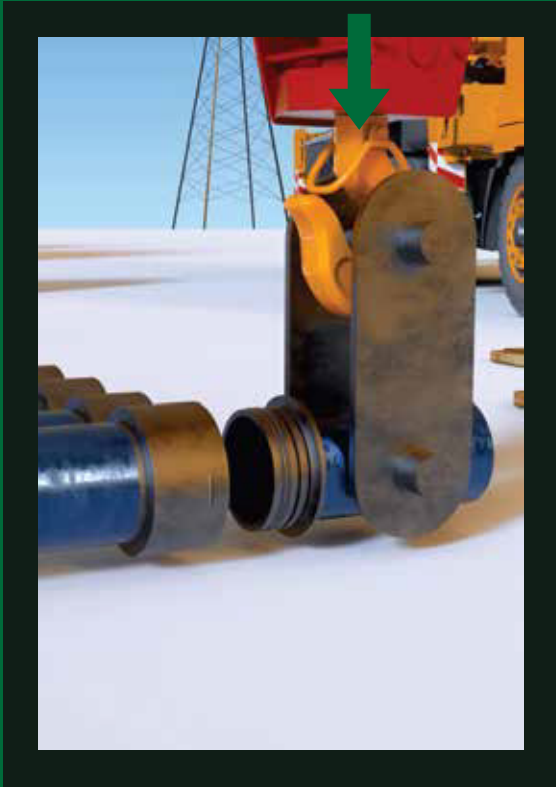

Insert Pipe

Remove Chains

Centralize Riser Pipe

Insert O-Rings

Step 9 – Connect Riser Pipe with Pump Adaptor

- Install the Guide wheel with the lifting device to the ZSM riser pipe to insert the male side of the Lifting device into the female side of the ZSM riser pipe while it is in a Horizontal position, and add the Wheel lifting device on the other end of the male side to lift the riser pipe from a horizontal to vertical position.
- Secure it with the 2 x chains into its positioned grooves to lift the ZSM riser pipe from horizontal to vertical position and move it to the borehole.
- Insert the 3 x O-rings to the male end of the riser pipe, ensuring the surfaces are clean and free of any dust.
- Make use of standard Vaseline to rub on the O-Rings before installing them on the male end, to ensure easier installation and that the O-Rings do not damage.
- Centralise the riser pipe with the centre of the Pump adaptor.
- Lower the male end of the riser pipe into the female coupling ensuring the anti-rotation slots are aligned.
- Insert the 2 Chains into their grooves to secure the lift and place the dust cover plates to prevent dirt entering the chain grooves.
- Ensure that the cabling is rooted correctly.

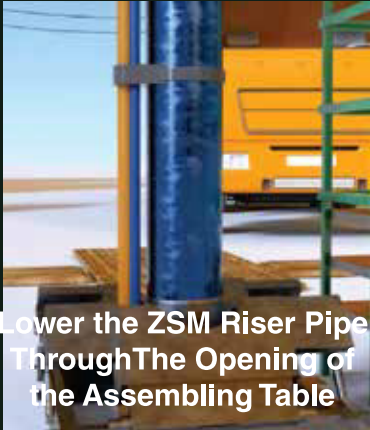

Lower the ZSM Riser Pipe Through The Opening of the Assembling Table

Lower the ZSM Riser Pipe Through the Opening of the Assembling Table



Pipe While Lowering

Install the HCL Cable Clamps to the ZSM Riser Pipe while Lowering the Column



Remove the 2 Chains From the Grooves of the ZSM Coupling to Loosen the Lifting Device



Close both Clamp Doors While the Crane Lower the Pump Unit Until ZSM Collar Seats on the Door Clamps



HCL Clamps

36 Step 10 – Lowering riser pipe and clamp cable with HCL Clamps.

- Slowly lift the complete unit to manually open the clamp doors of the assembling table and carefully lower the ZSM riser pipe through the opening of the assembling table.
- Guide the cables and make use of the cable dispensers to ensure that there is no slack in the borehole.
- Insert the PVA tube and attach it on the same level as the non-return valve of the pump; this tube will be used to lower the level transducer once the installation is complete.
- Lower the riser pipe in the borehole casing, attach the power cables to the side of the 11m riser pipe with the custom designed HCL cable clamps.
- The Smart plastic clamps will be placed 3m apart from one another on each length of the ZSM pipe, which will keep the cables in place and cable strap in between the smart clamp (Ensure the cable is adjusted enough by using the HCL Torque wrench supplied).
- Once the equipment is lowered deep enough for the clamp doors to be closed again. Close both clamp doors while the Crane slowly lowers the pump unit until the ZSM collar seats on gate of the door clamps (ensure cables are lying properly in cable clots before closing doors).
- Remove the 2 chains from the grooves of the ZSM coupling to loosen the Lifting device from the ZSM female end with a Mobile Crane, the Pump unit total weight will rest on the assembling table.
- After completion of the male and female connection, the same procedure will be followed as stated above to complete the installation of the riser pipes until the installed depth is reached.
- Close both doors of the assembling table, to guide the cables through to dedicated cable slots in the assembling table before closing the doors completely.
- Lower the complete system until the support bracket rests on the assembling table and secure the bolts to ensure the installation is safe. (Note: that the assembling table will then form part of the header for permanent installation).



**Adaptor Piece
ZSM to Flange**

ZSM Supporting Pipe

ZSM Assembly Table

38 Step 11 – Connect the ZSM pipe support to Assembling Table

- Once the installation depth has been reached, the last riser pipe to be installed is the Supporting pipe, which will be lifted from a horizontal position to the vertical.
- Insert the 3x O-rings to the male end of the riser pipe, ensure the surface is clean and free of any dust.
- Make use of standard Vaseline to rub on the O-Rings before installing them on the male end, to ensure for easier installation and the O-Rings do not damage.
- Centralise the riser pipe with the centre of the Pump adaptor as per point 48.
- Lower the male end of the riser pipe into the female coupling, ensuring the anti-rotation slots are aligned.
- Insert the 2 chains into their grooves to secure the lift and place the dust cover plates to prevent dirt entering the chain grooves.
- Slowly lift the complete unit to manually open the clamp doors of the assembling table and carefully lower the ZSM riser pipe through the opening of the assembling table.
- Close both doors of the assembling table be sure to guide the cables through to dedicated cable slots in the assembling table before closing the doors completely.
- Lower the complete system until the support brackets rest on the assembling table and secure the bolts to ensure the installation.
- Install the adaptor piece with gasket over female coupling of the supporting pipe which changes from ZSM to flange.

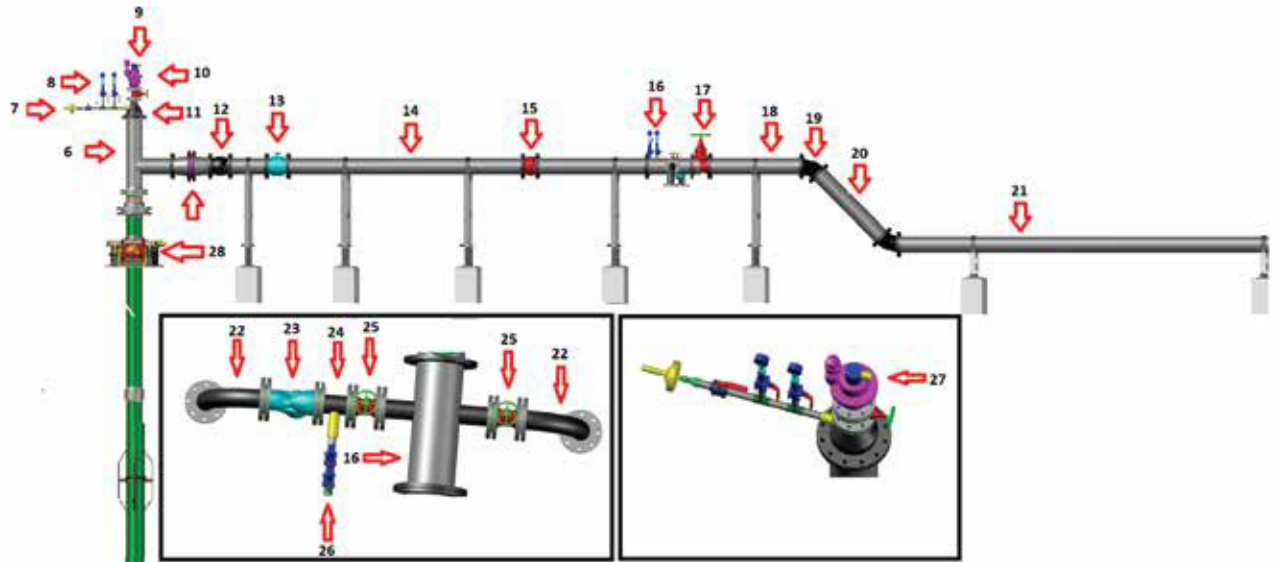

1	Submersible Motor
2	Submersible Multistage Pump
3	Manifold equipped with 2x spring loaded NRV's
4	DN200 Carl Hamm ZSM Pipes
5	Pipe Centralizer for deep wells
6	DN200 T-Piece 1000mm lg with DN200 Branch Pipe 500mm lg
7	Pressure Transducer unit
8	Bottom entry glycerine filled and bottom entry dry with limit switches bounce negative and positive gauges
9	D-060-HFNS combination air valve
10	DN80 RSV gate valve
11	Concentric reducer
12	DN200 single free type bellow expansion joint
13	DN200 mag flow in line flowmeter
14	DN200 spool piece 1200mm lg
15	DN200 ultra PN16 silent check valve flanged short pattern
16	DN200 spool piece 740mm long with 2 x branch pipes 250mm long
17	DN200 RSV gate valve
18	DN200 spool piece 1250mm long
19	DN200 45 degrees elbow bend
20	DN200 spool piece 1250mm long
21	MINE SUPPLY!!!!
22	DN80 90 degrees elbow bend for scour valve
23	DN80 ultra quick acting relief valve 16 bar
24	DN80 150mm long spool piece with weld on socket
25	DN80 RSV gate valve
26	Bottom entry glycerine filled and bottom entry dry with limit switches bounce negative and positive gauges
27	Turck airflow captor
28	Pressure transducer



Install the Header works in the following sequence:

- Lift and install the T-Piece ring mark 1 on top of the ZSM adaptor piece and secure with bolts.
- Lift and install Concentric reducer DN200 to DN80 ring mark 2, be sure to place the gasket between fitment and secure with bolt sett.
- Fit the DN80 RSV Gate valve ring mark 4.
- Fit the double action air valve on top ring mark 5.
- Assemble the Maric ring mark 6 in between the Concentric reducer ring mark 7.
- Then lift the unit to be fitted to the t-piece.
- Fit the bellow ring mark 9.
- Fit the Spool piece ring mark 8.
- Fit the Silent check valve ring mark 10.
- Pre-assemble unit 11 with all accessories and fit it to the pipe works.
- Fit spool piece ring mark 15.
- Fit the flow meter ring mark 16.
- Fit the spool piece ring mark 17.
- Fit the RSV Gate valve ring mark 18.
- Fit spool piece ring mark 19.
- Fit the 45-degree elbow ring mark 20 with the in between spool pipe ring mark 21.
- Fit the last pipe ring mark 22.

STARTUP METHODOLOGY COMPARISON OF PUMP CONTROL

OPTION 1 DOL STARTER

During starting of electrical motors, the motor experiences an inrush electrical current. If the motor is started with a DOL starter, this inrush may reach a magnitude of at least six times the motor's full-load current. With a DOL starter, repeated starting may cause excessive heat buildup in the motor windings. This method of starting also causes additional torsional stress on the motor and pump.

Stopping a motor with a DOL starter removes the power from the motor instantaneously, therefore removing the motive power from the pump at the same time. At this point, the water column in the pipes will still be moving forwards. Due to the immediate pump stop action, water separation may occur in the pipe. Typically, a vacuum is created between the moving column of water and the non-moving section. This vacuum will attempt to pull the two columns together, causing an effect called "water hammer" when the two columns meet.

During starting, a similar effect can occur as a result of the sudden motive power applied to the water column. This effect may cause major problems, from noise and vibration to pipe collapse.

This method offers no speed control.

OPTION 2 SOFT STARTER

(Not recommended for Pumps with water lubricated sleeve bearings - Ramp time too slow)

The Soft Starter is a starting method that reduces the starting inrush current of the motor during starting by applying a reduced voltage to the motor and thereafter controlling the ramp-up to full voltage over a timed period. The inrush current is typically limited to three to four times full-load current. Motor stopping is similarly controlled, with the applied voltage ramped down over a timed period. During both stopping and starting, the water column velocity is controlled by the ramped action taking place. Some soft starters available commercially, employ a starting/stopping voltage/time curve that has been specifically designed to minimise water hammer during both starting and stopping of pumps, thereby reducing the potential harmful consequences of this effect.

This method offers no speed control.

OPTION 3 VARIABLE SPEED DRIVE (VSD)

This type of device is also referred to as a Variable Frequency Drive (VFD)

A VSD controls motor starting, stopping and running speed by controlling the frequency of the voltage applied to the motor. Various methods of Voltage/Frequency ratio control is employed by manufacturers to provide increased torque at lower motor speeds.

As the motor is accelerated smoothly from standstill to the desired running speed, motor inrush current is typically reduced to less than 2 x motor full-load current, depending on the type of VSD used and the set-up of the system. The smooth acceleration from standstill also assists with the elimination of torsional stresses during starting. Stopping is similarly controlled by smoothly decelerating the motor to standstill. The smooth acceleration/deceleration ensures that there is no sudden change in flow or pressure in the pipeline during starting/stopping of the pump. Water hammer can therefore be virtually eliminated, provided the ramp-up and down times are specifically set-up for the specific application.

An additional advantage of using a VSD is that motor speed can be adjusted to deliver a specific delivery by the pump. The VSD reduces the risk of possible damage caused by DOL or Soft Starters and increases the operational life of the pipe, pump and motor.

This method offers speed control.

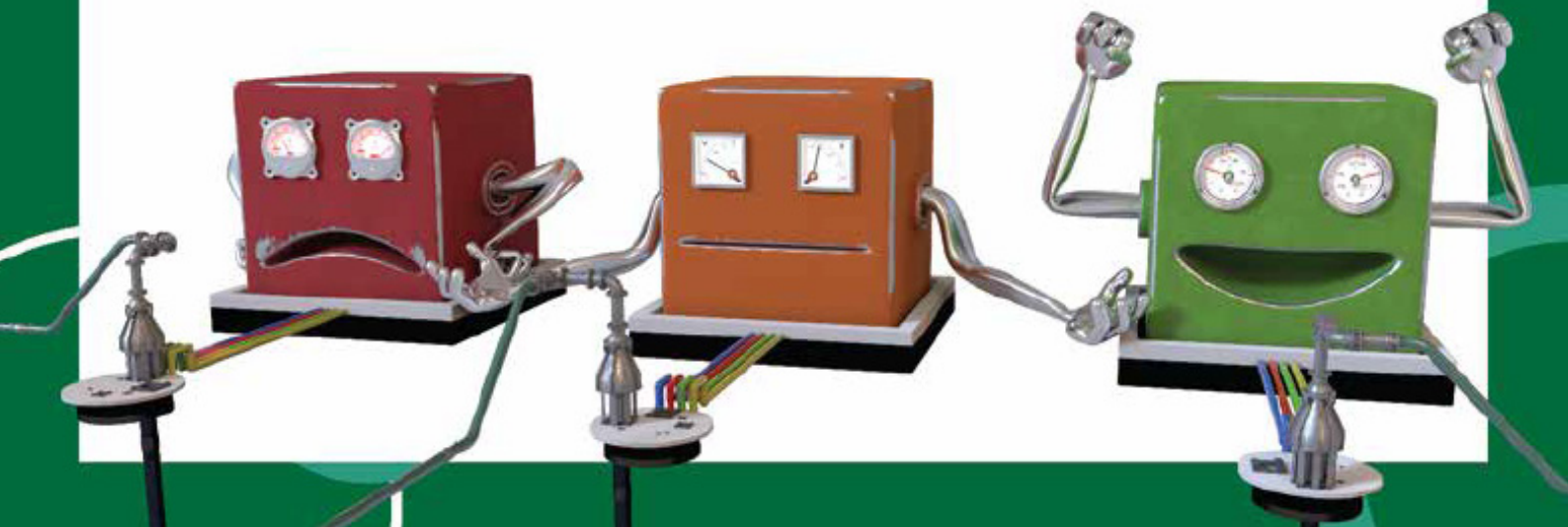

42 Startup Methodology Comparison Of Pump Control

VSD

Ramp Up to 30Hz in 1 Second
Ramp Down from 30Hz in 1 Second

Electrical Compliance

Protection settings

- Reverse Phase
- Phase Loss
- Phase Imbalance
- Under Voltage
- Over Voltage
- Under Current
- Event Logging
- Over Current
- Surge Arrestors
- Earth Protection
- Site earthing

Electrical Equipment

- Instrumentation
- Flow Meter
- Pressure Transducer
- Level Control



Pressure Transmitter



Field Isolator

Step 13 – Electrical Equipment

- The power cables can now be removed from the cable drums which must be rooted into the Field isolator next to the borehole.
- The Electricians will then complete the cable connection inside the field isolator.
- Lower the Level transmitter into the blue tube until it reaches the installation depth.

Carl



Hamm

PIPES | PUMPS | SOLUTIONS

Carl



Hamm

PIPES | PUMPS | SOLUTIONS

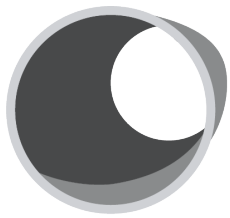

Carl Hamm

PIPES | PUMPS | SOLUTIONS

Competence, experience, innovative thinking, modern manufacturing plants and motivated employees form the basis of our services.

With the flexibility of a modern, medium-sized company and the experience of our over 90-year history, we are well equipped to meet the requirements of the future.

The numerous certifications and technical approvals all ensure that we serve our customers with the highest quality standards through the complete project phases.

Our product range focuses on water, waste water and power industries, tunnel construction and well-sinking as well as open-pit and underground mining.

We, as a competent partner, ensure an added value for specific customer needs: from the conceptual planning to professional production and punctual delivery.



Röhrenwerk Kupferdreh Carl Hamm GmbH

Gasstraße 12
D-45257 Essen
Germany

dieter.schmitz@carl-hamm.com
www.carl-hamm.de
Tel.: +49 (021) 848 1723
Fax: +49 (201) 848 1770
Mobile: +49 (151) 503 12104

Carl Hamm PPS (Pty.) Ltd

2 Bickford Street, Founders Hill, Lethabong,
1609

chris@carl-hamm.co.za
www.carl-hamm.co.za
Tel.: +27 (0)72 256 0926